



### LED FLOOD - MODEL SFLEDFL150SMDLM

Our compact LED Flood light adopts a new 3rd generation LED Flood light heatsink, Ultra slim sleek design. LED Flood light reflector and heatsink integrated, Pure aluminum structure for heat dissipation. New processing technology of LED light fixtures ensuring performance and long service life. Professional optical design, lumen efficiency can be increased by 50%, More than 130lm/w. 3 or 5-year warranty available

#### Technical Specifications

Product Name:	Compact LED Flood
Model NO.:	SFLEDFL150SMDLM
Power:	150W
LED Chip	Phillips SMD LED
Lamp housing	aluminum
Power Factor:	PF>0.95
Input Voltage	85-265V AC
THD:	THD<10%
IP Grade:	IP65
CRI:	Ra> 80
Lumen:	150W>19500lm
Beam Angle:	110°
Color:	Warm white / nature white/ Cool White
Working Temp:	-40~60°C
Warranty	3 or 5 Years warranty (Life time is more than 50000hours)
Certification	IEC60598-1 / IEC 60598-2-5 / IEC62031

## Light Distribution 110 Deg

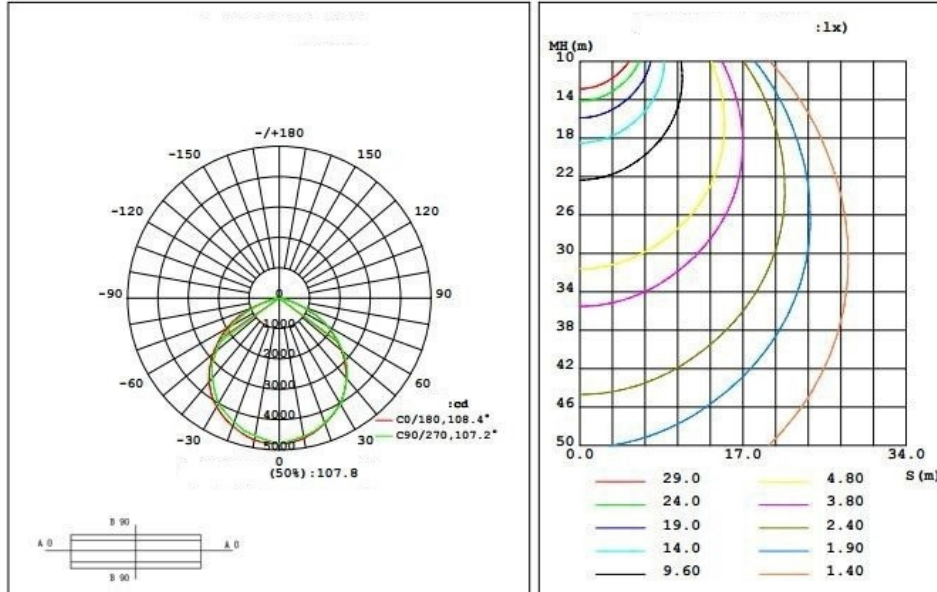

## Product Dimensions

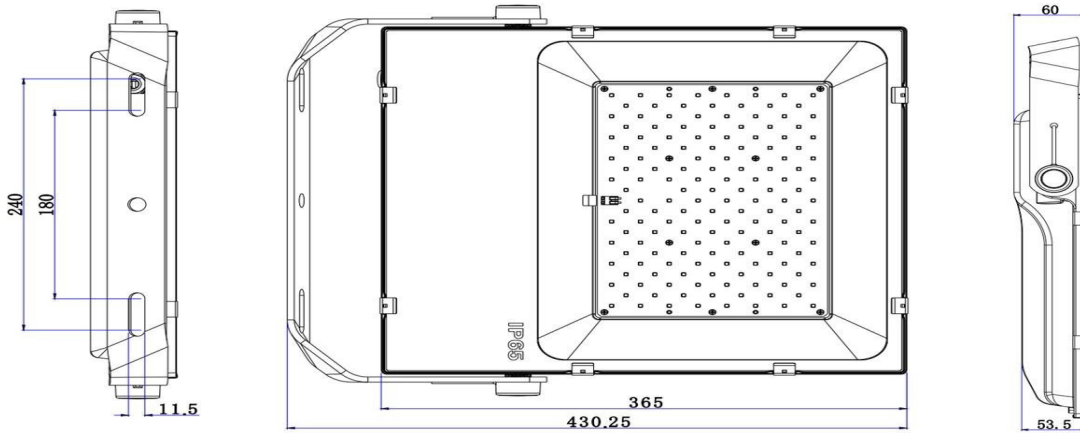

## Packing

1pcs in a carton. Carton Size: 51\*43\*13.5cm. 6.5KG/CARTONS

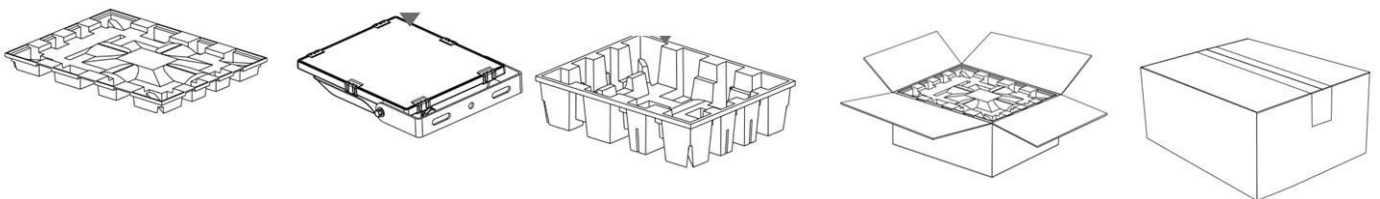

### Compact and Innovative Design

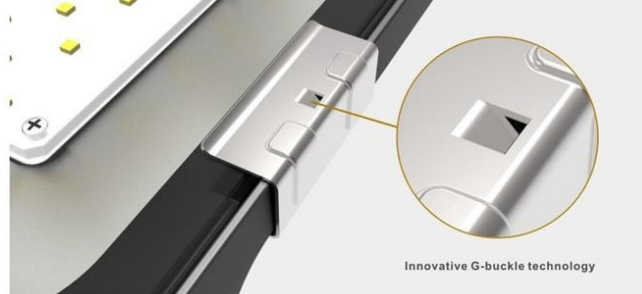
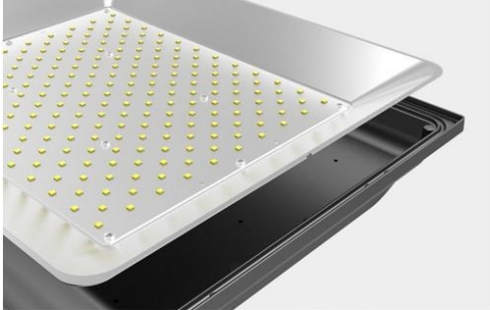

**Reflector and heat sink integrated**    **Design innovation, effective protection**



Protection grade reaches Ip65



Anti-Level-17 hurricane



Adjustable 270° Angle

