



### LED FLOOD - MODEL SFLEDFL120SMDLM

Our compact LED Flood light adopts a new 3rd generation LED Flood light heatsink, Ultra slim sleek design.  
 LED Flood light reflector and heatsink integrated, Pure aluminum structure for heat dissipation.  
 New processing technology of LED light fixtures ensuring performance and long service life.  
 Professional optical design, lumen efficiency can be increased by 50%, More than 130lm/w.  
 3 or 5-year warranty available

#### Technical Info

Product Name:	Compact
Model NO.:	SFLEDFL120SMDLM
Power:	120W
LED Chip	Philips SMD LED
Lamp housing	aluminum
Power Factor:	PF>0.95
Input Voltage	85-265V AC
THD:	THD<10%
IP Grade:	IP65
CRI:	Ra>80
Lumen:	120W>15600lm
Beam Angle:	110°
Color:	Warm white / nature white/ Cool White
Working Temp:	-40~60
Warranty	5 Years warranty (Life time is more than 50000hours)
Certification	IEC60598-1 / IEC 60598-2-5 / IEC62031

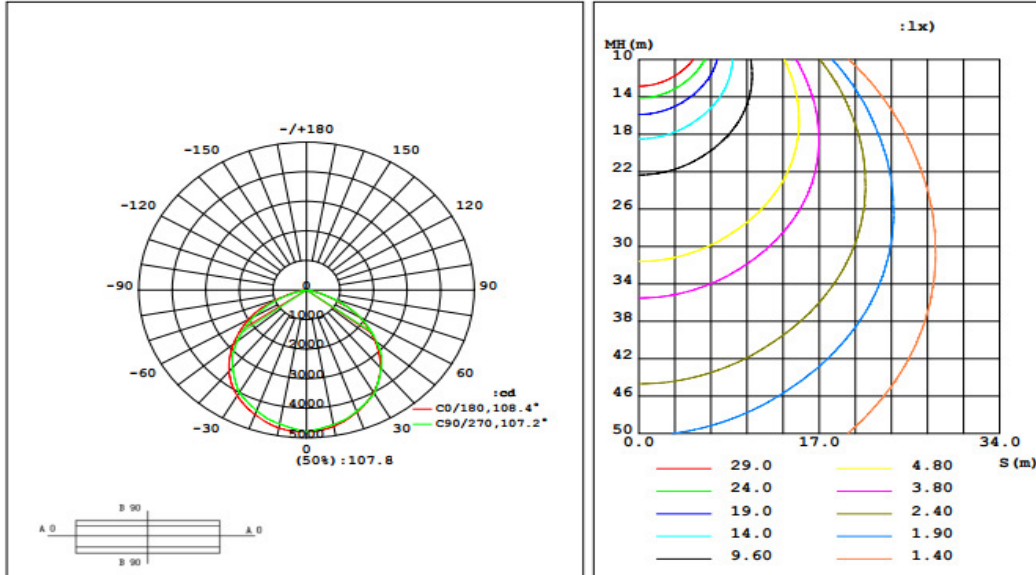

### Product Dimensions

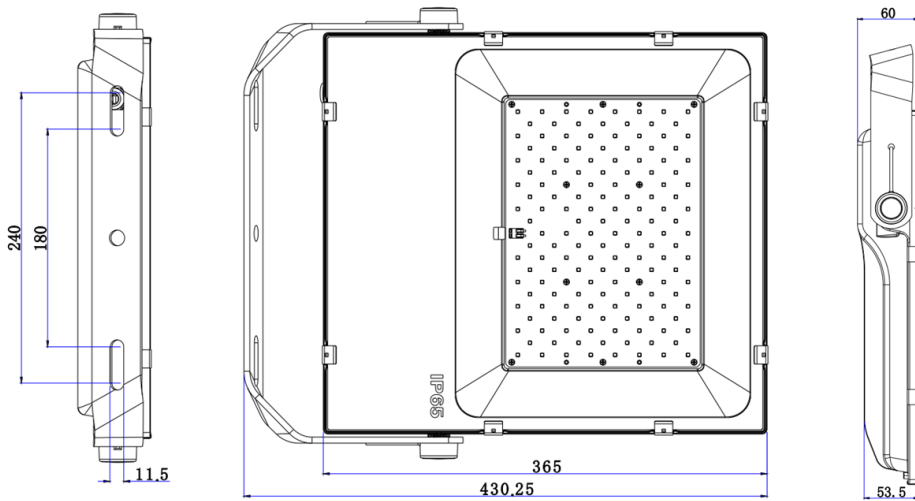

### Packaging

1pcs in a carton. Carton Size: 51\*43\*13.5cm. 6.5KG/CARTONS

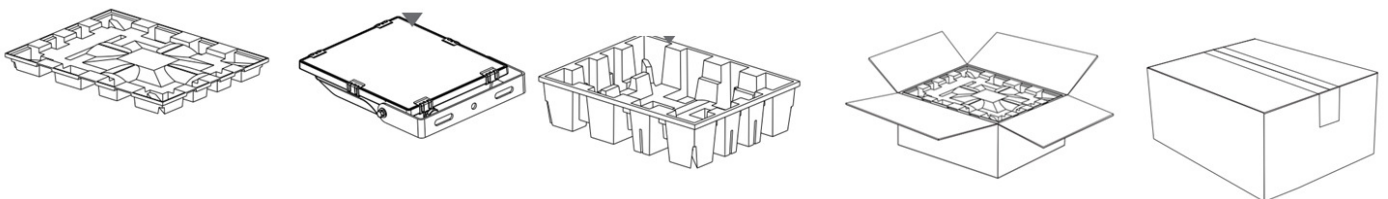

### Compact & Innovative Design

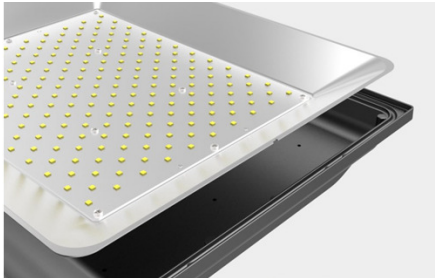

Reflector and heat sink integrated

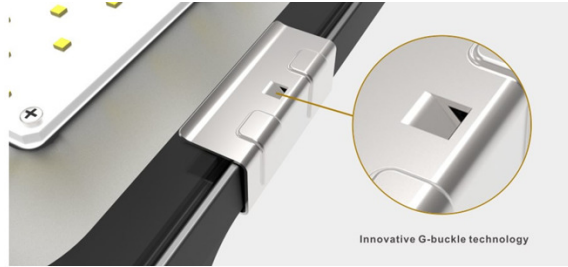

Design innovation, effective protection



Protection grade reaches Ip65



Anti-Level-17 hurricane



Adjustable 270 ° Angle

