



LED FLOOD - MODEL SFLEDFL30SMDLM

Our compact LED Flood light adopts a new 3rd generation LED Flood light heatsink, Ultra slim sleek design. LED Flood light reflector and heatsink integrated, Pure aluminum structure for heat dissipation. New processing technology of LED light fixtures ensuring performance and long service life. Professional optical design, lumen efficiency can be increased by 50%, More than 130lm/w. 3 or 5-year warranty available

Technical Specifications

Product Name:	Compact LED Flood
Model NO.:	SFLEDFL30SMDLM
Power:	30W
LED Chip	Phillips SMD LED
Lamp housing	aluminum
Power Factor:	PF>0.95
Input Voltage	85-265V AC / 12 VDC
THD:	THD<10%
IP Grade:	IP65
CRI:	Ra> 80
Lumen:	30W>3900lm
Beam Angle:	110°
Color:	Warm white / nature white/ Cool White
Working Temp:	-40~60°C
Warranty	3 - 5 Years warranty (Life time is more than 50000hours)
Certification	IEC60598-1 / IEC 60598-2-5 / IEC62031

Light Distribution 110 Deg

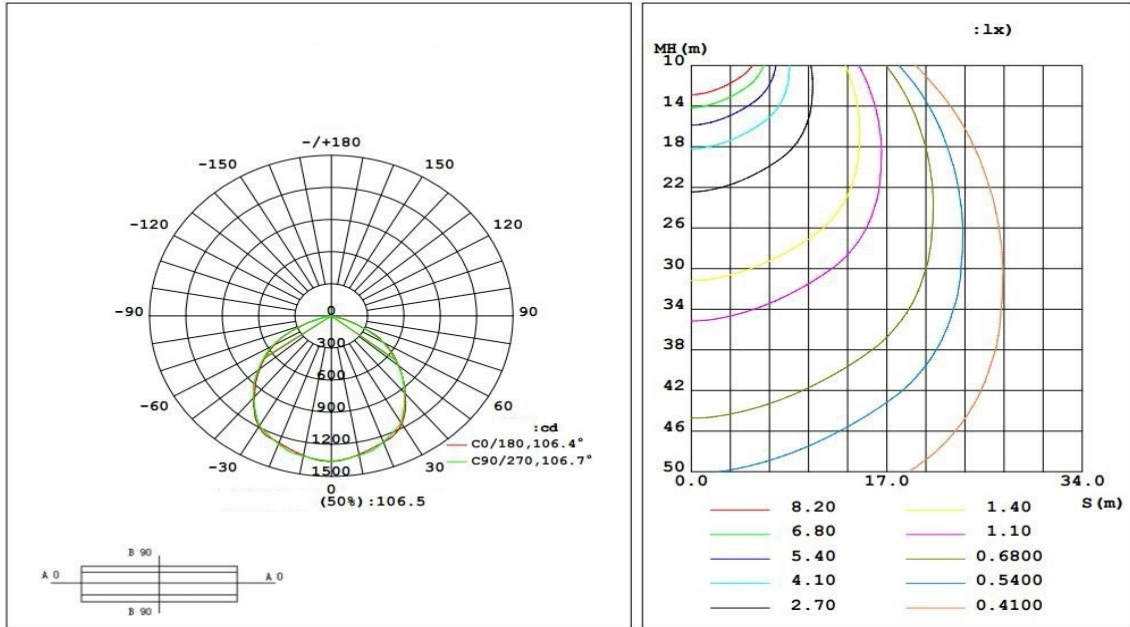

Product Dimensions

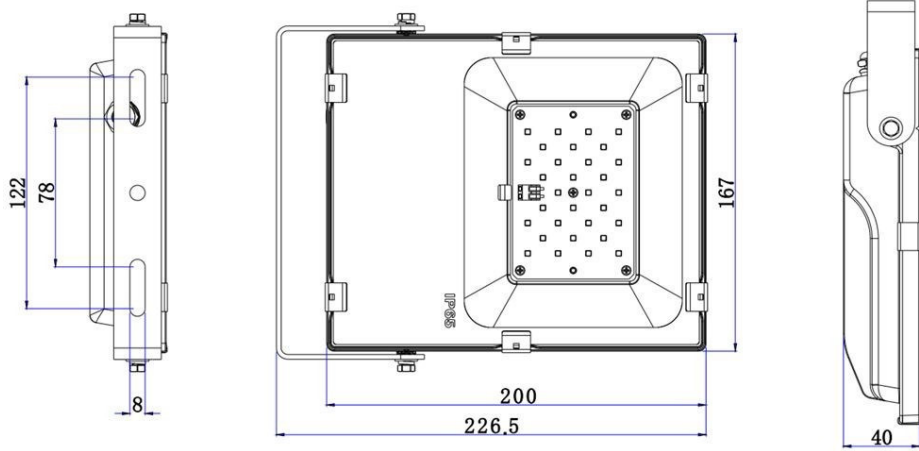

Packing

20pcs in a carton. Carton Size: 53.5*40.5*26cm. 20KG/CARTONS

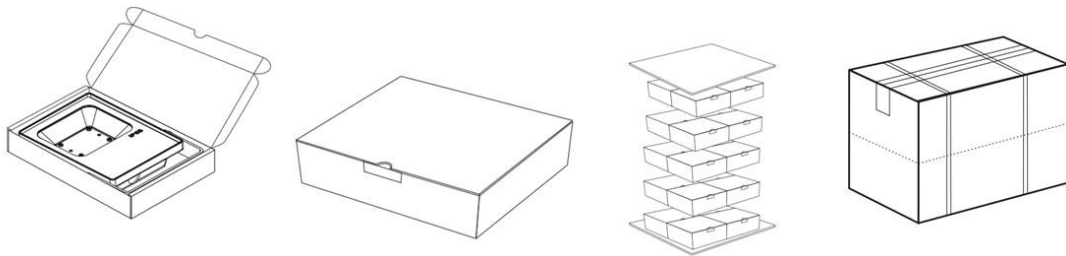

Compact and Innovative Design

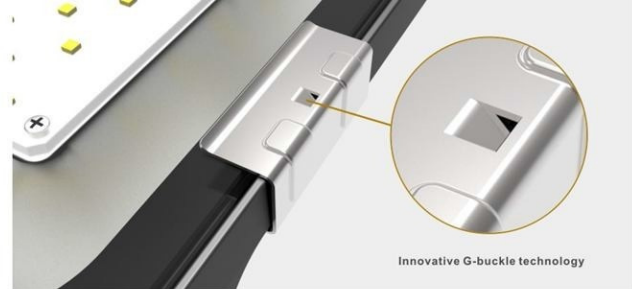
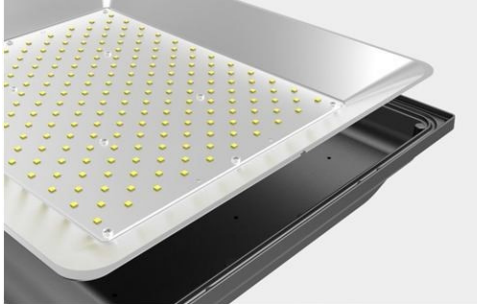

Innovative G-buckle technology

Reflector and heat sink integrated

Design innovation, effective protection



Protection grade reaches Ip65



Anti-Level-17 hurricane



Adjustable 270 ° Angle

